

Linear bearing flange

ST-L series-**ST5L**

参数信息:

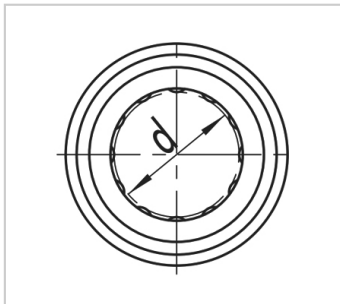
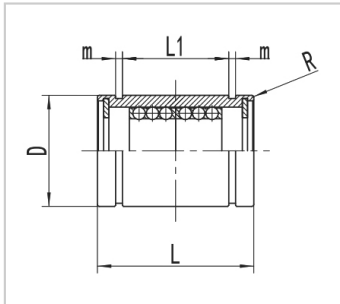

Aluminum alloy retainer :	ST5L
Main dimensions and tolerances (mm) :	
dr :	-
tolerance :	0~-0.008
D :	10
tolerance :	0~-0.009
L :	15
tolerance :	0~-0.12
Main dimensions and tolerances (mm) flange :	
L1 :	8
m :	1.1
r :	0.4
Maximum travel distance (um) :	6
Number of ball columns :	6
Rated load :	
C(N) :	205
Co(N) :	210
Weight (g) :	5

: