

Linear bearing flange

ST-L series-**ST8L**

参数信息:

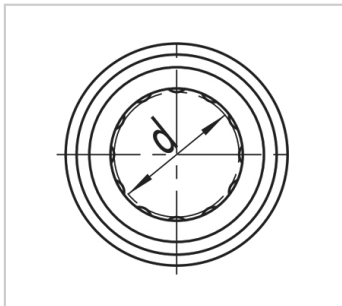
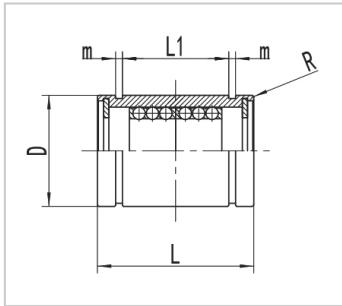

Aluminum alloy retainer :	ST8L
---------------------------	------

Main dimensions and tolerances (mm) :

dr :	-
tolerance :	0~-0.009
D :	15
tolerance :	0~-0.011
L :	24
tolerance :	0~-0.2

Main dimensions and tolerances (mm) flange :

L1 :	15.3
m :	1.1
r :	0.4

Maximum travel distance (um) :	8
--------------------------------	---

Number of ball columns :	6
--------------------------	---

Rated load :	
C(N) :	510
Co(N) :	555

Weight (g) :	17
--------------	----

: